

ZERO-MAX

ServoClass® Couplings



ServoClass® Couplings for Today's Demanding Motion Applications

- ServoClass Couplings are ideal for **precise positioning, high speed, reversing loads**, and applications requiring **high repeatability**
- **High Precision and Performance** ideal for demanding servo motor motion control applications
- **Zero backlash** and low hysteresis ensure repeatable precise positioning
- **High torsional stiffness** for use in dynamic and reversing applications
- **Low inertia** for high speed applications
- **Low reaction loads** reduce stress and increase system lifespan
- **Eco-Friendly**, RoHS Compliant with no banned substances



- Available in 14 sizes in single and double disc models
- Double disc models provide highest misalignment capability
- Operating temperature range is -22° to +212°F (-30° to +100°C)
- Torque ratings range from 0.25 to 250Nm (2.2 to 2,213 in-lb)
- Hubs and center members manufactured of aluminum alloy for strength, durability, and are treated to prevent oxidation and to preserve appearance
- Disc packs are made of 304 stainless steel
- Couplings are precisely assembled using high strength, corrosion resistant fasteners
- Integral clamp style hubs provide fast, easy mounting, and a secure shaft connection
- RoHS compliant – manufactured of RoHS compliant materials and contains no banned substances

Today's servo motor applications are more demanding than ever. The precision positioning requirements and high reverse load characteristics of servo motor applications necessitate a coupling design that specifically addresses the needs of these sophisticated systems.

Attributes of a Superior Servo Motor coupling

- High Torsional Stiffness
- Zero-Backlash
- Misalignment capability
- Low Reaction Loads
- Low Inertia

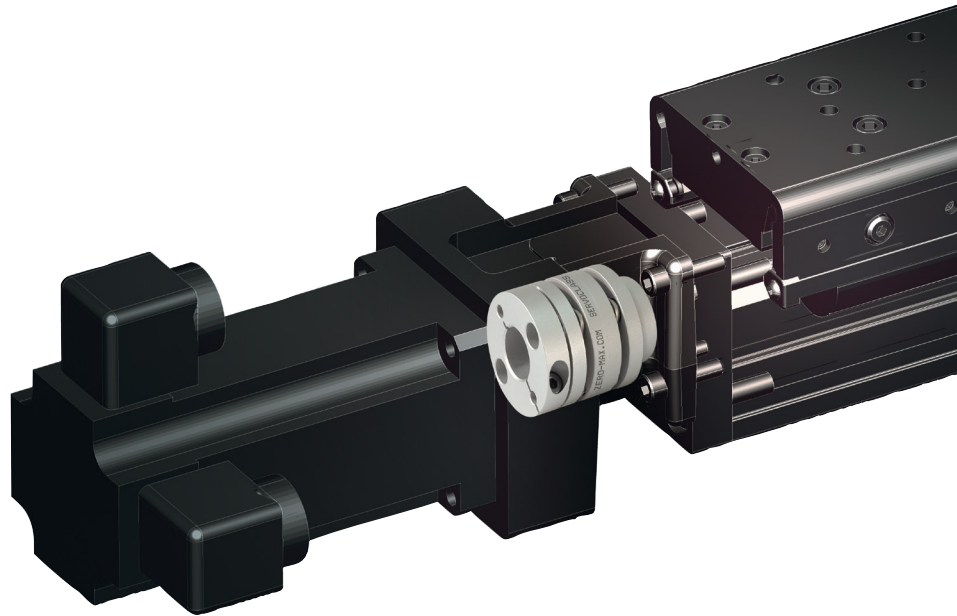

High Torsional Stiffness is an important quality of any high performance coupling. Low torsional stiffness couplings will reduce system performance and accuracy. The high torsional stiffness characteristic of the Zero-Max ServoClass coupling provides precise position accuracy and increases the system resonant frequency above the resonant operating frequency of most equipment.

Zero-Backlash is a key requirement of a high performance servo coupling. A coupling may be considered zero backlash and still have a large amount of torsional windup. Zero Backlash along with High Torsional Stiffness allows the ServoClass Coupling to maintain the same angular relationship between the input and output shaft without lost motion.

High Misalignment Capacity of a coupling is also important in a motion control system. Usually, the alignment of a well manufactured servo system will be very good. Over time and under high load conditions, this alignment may deteriorate. The ServoClass coupling will allow for this misalignment while remaining a torsionally stiff and zero backlash connection.

Low Reaction Loads on the system's bearings and connected components is not only desirable, it is one of the primary reasons for using a flexible coupling. The Zero-Max ServoClass coupling design provides flexibility for inevitable misalignment, therefore minimizing the reaction loads to the servo motor and system bearings to provide maximum life.

Low Inertia is a critical feature of a superior servo coupling. The inertia should be low so that it does not add significantly to the overall inertia of the servo system. The lower the inertia, the less energy required by the motor to move the system, and therefore higher acceleration is possible. Zero-Max ServoClass couplings are made from a high-strength aluminum alloy, resulting in very low inertia.

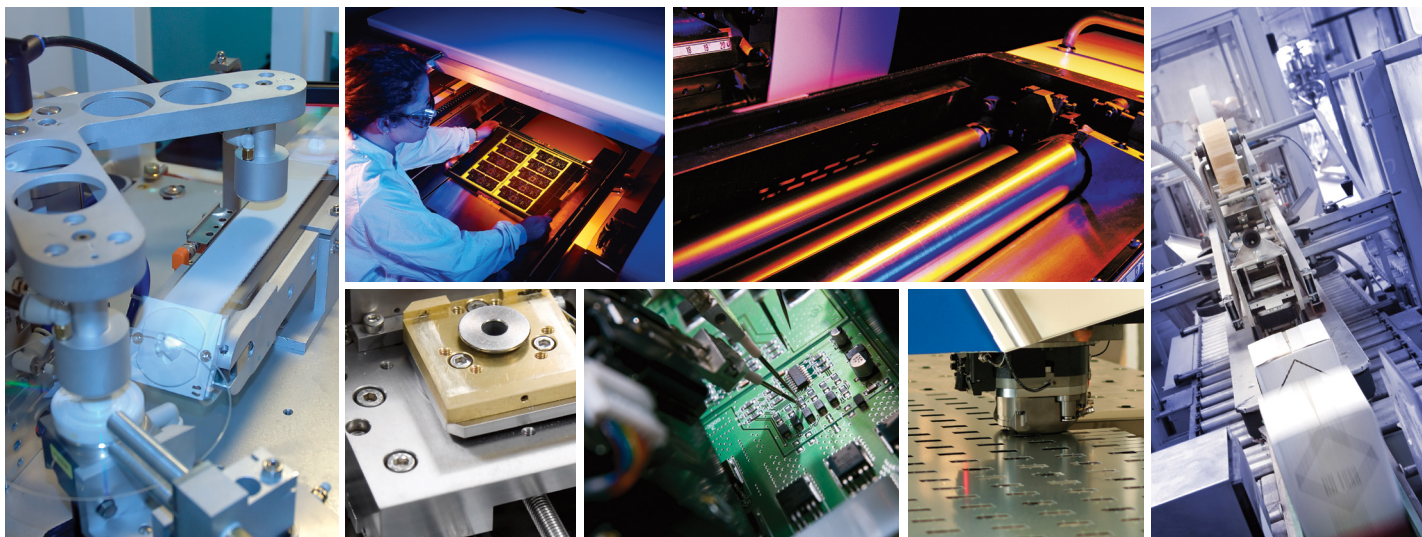

- For high performance servo motor and demanding motion control applications
- High torsional stiffness for use in precision positioning applications
- High misalignment capacity with low reaction loads
- Eco-Friendly, adapted to RoHS Directive with no banned substances
- Low inertia for high speed applications
- Zero backlash and low hysteresis ensures repeatable precise positioning



Double Disc Specifications

Model	Operating Torque in-lbs (Nm)	Maximum RPM rpm	Torsional Stiffness in-lbs/deg (Nm/rad)	Axial Stiffness lbs/in (N/mm)	Misalignment Capacity			Moment of Inertia lb-in ² (kgm ² x10 ⁻⁶)	Weight ounce (gram)	Style
					Parallel inch (mm)	Angular degree	Axial ± inch ± (mm)			
SC002R	2.2 (0.25)	10,000	14 (95)	97 (17)	0.001 (0.03)	0.5	0.002 (0.08)	0.0002 (0.07)	0.14 (4)	C
SC005R	5.3 (0.6)	10,000	39 (250)	400 (70)	0.002 (0.05)	0.5	0.004 (0.10)	0.0012 (0.37)	0.35 (10)	C
SC010R	8.9 (1.0)	10,000	108 (700)	400 (70)	0.004 (0.11)	1	0.008 (0.20)	0.0027 (0.80)	0.53 (15)	C
SC020R	18 (2.0)	10,000	286 (1,850)	183 (32)	0.006 (0.15)	1	0.013 (0.33)	0.012 (3.40)	1.3 (35)	C
SC025R	35 (4.0)	10,000	432 (2,800)	171 (30)	0.006 (0.16)	1	0.015 (0.38)	0.018 (5.26)	1.4 (40)	C
SC030R	44 (5.0)	10,000	618 (4,000)	183 (32)	0.007 (0.18)	1	0.016 (0.4)	0.025 (7.33)	1.9 (54)	A
								0.032 (9.39)	2.2 (60)	B
								0.039 (11.5)	2.4 (68)	C
SC035R	89 (10)	10,000	1,390 (9,000)	320 (56)	0.009 (0.24)	1	0.020 (0.5)	0.092 (26.8)	4.3 (122)	C
SC040R	106 (12)	10,000	1,545 (10,000)	228 (40)	0.009 (0.24)	1	0.024 (0.6)	0.101 (29.5)	4.3 (122)	A
								0.123 (36.1)	4.8 (136)	B
								0.146 (42.6)	5.3 (151)	C
SC050R	221 (25)	10,000	2,472 (16,000)	137 (24)	0.011 (0.28)	1	0.031 (0.8)	0.331 (96.9)	8.7 (246)	A
								0.407 (118.9)	9.7 (275)	B
								0.483 (141.7)	10.7 (304)	C
SC055R	354 (40)	10,000	3,863 (25,000)	123 (21.5)	0.012 (0.31)	1	0.033 (0.84)	0.891 (261.3)	16.1 (459)	C
								0.862 (252)	15.5 (440)	A
								1.08 (315.7)	17.6 (498)	B
SC060R	531 (60)	10,000	5,407 (35,000)	218 (38)	0.013 (0.34)	1	0.035 (0.9)	1.29 (377)	19.5 (556)	C
								3.54 (1,034)	37.0 (1,051)	C
								6.08 (1,776)	48.4 (1,373)	C
SC080R	885 (100)	10,000	10,813 (70,000)	366 (64)	0.02 (0.52)	1	0.04 (1.10)	6.08 (1,776)	48.4 (1,373)	C
SC090R	1,593 (180)	10,000	7,724 (50,000)	308 (54)	0.02 (0.52)	1	0.05 (1.30)	9.26 (2,704)	60.2 (1,707)	C
SC100R	2,213 (250)	10,000	9,268 (60,000)	317 (55)	0.02 (0.52)	1	0.06 (1.48)			C

• Moment of Inertia and Weight are measured with the maximum bore diameters

If the shafts of the equipment are smaller than the ID of the flex element they may be extended into the interior of the coupling. The ends of the shafts must never touch each other or the other hub.

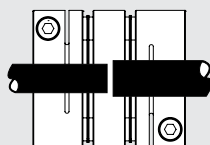

Style of coupling is dependent on the size of the coupling and bore combination selected. Therefore, the coupling could be comprised of the combinations shown to the right.



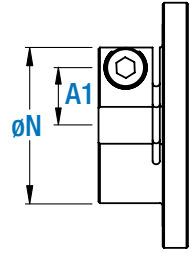
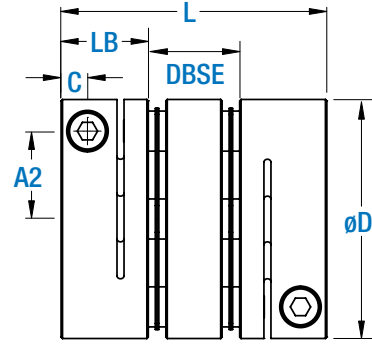
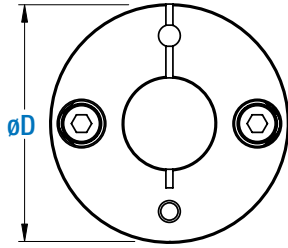
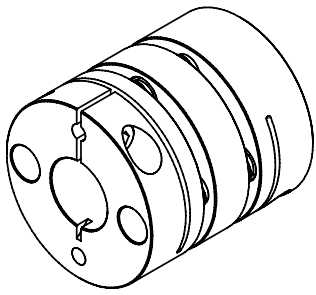

Reduced hub **

Double Disc Dimensions

Model	Bores		Outside Diameter	Overall Length	Hub Length	Reduced Hub Diameter	Distance Between Shaft Ends	Inside dia. of the flex disc	Clamp Screw to Bore (on reduced hubs)	Clamp Screw	Clamp Screw to End of Hub C	Clamp Screw Size	Tightening Torque
	Min inch (mm)	Max inch (mm)											
SC002R	0.125 (3)	0.1875 (5)	0.47 (12)	0.618 (15.7)	0.232 (5.9)	-	0.153 (3.9)	0.224 (5.6)	-	0.146 (3.7)	0.074 (1.9)	M1.6	2 (0.23)
SC005R	0.125 (3)	0.1875 (6)	0.63 (16)	0.913 (23.2)	0.309 (7.85)	-	0.295 (7.5)	0.256 (6.5)	-	0.189 (4.8)	0.098 (2.5)	M2.0	3.5 (0.4)
SC010R	0.125 (3)	0.3125* (8)*	0.748 (19)	1.02 (25.9)	0.36 (9.15)	-	0.299 (7.6)	0.335 (8.5)	-	0.228 (5.8)	0.124 (3.15)	M2.5*	9* (1)*
SC020R	0.1875 (4)	0.4375 (11)	1.024 (26.0)	1.272 (32.3)	0.423 (10.75)	-	0.425 (10.8)	0.417 (10.6)	-	0.374 (9.5)	0.130 (3.3)	M2.5	9 (1)
SC025R	0.250 (5)	0.500 (14)	1.142 (29.0)	1.291 (32.8)	0.423 (10.75)	-	0.445 (11.3)	0.571 (14.5)	-	0.433 (11.0)	0.130 (3.3)	M2.5	9 (1)
SC030R	0.1875** (5)**	0.625 (16)	1.339 (34.0)	1.488 (37.8)	0.488 (12.4)	0.850 (21.6)	0.511 (13.0)	0.571 (14.5)	0.315 (8)	0.492 (12.5)	0.148 (3.75)	M3	13 (1.5)
SC035R	0.250 (6)	0.750 (19)	1.535 (39.0)	1.890 (48)	0.610 (15.5)	-	0.669 (17.0)	0.669 (17)	-	0.551 (14)	0.177 (4.5)	M4	30 (3.4)
SC040R	0.3125** (8)**	0.9375 (24)	1.732 (44.0)	1.890 (48)	0.610 (15.5)	1.165 (29.6)	0.669 (17.0)	0.768 (19.5)	0.433 (11)	0.669 (17)	0.177 (4.5)	M4	30 (3.4)
SC050R	0.375** (8)**	1.1875 (30)	2.205 (56.0)	2.354 (59.8)	0.807 (20.5)	1.496 (38)	0.740 (18.8)	1.024 (26)	0.571 (14.5)	0.866 (22)	0.236 (6)	M5	62 (7)
SC055R	0.4375 (10)	1.125 (30)	2.480 (63.0)	2.705 (68.7)	0.945 (24)	-	0.815 (20.7)	1.220 (31)	-	0.906 (23)	0.305 (7.75)	M6	124 (14)
SC060R	0.4375** (11)**	1.375 (35)	2.677 (68.0)	2.886 (73.3)	0.992 (25.2)	1.811 (46)	0.902 (22.9)	1.220 (31)	0.689 (17.5)	1.043 (26.5)	0.305 (7.75)	M6	124 (14)
SC080R	0.750 (18)	1.5625 (40)	3.228 (82.0)	3.858 (98)	1.181 (30)	-	1.496 (38.0)	1.496 (38)	-	1.102 (28)	0.354 (9)	M8	266 (30)
SC090R	1.000 (25)	1.750 (45)	3.622 (94.0)	3.882 (98.6)	1.181 (30)	-	1.520 (38.6)	1.654 (42)	-	1.339 (34)	0.354 (9)	M8	266 (30)
SC100R	1.3125 (32)	1.750 (45)	4.095 (104.0)	4.000 (101.6)	1.181 (30)	-	1.638 (41.6)	1.890 (48)	-	1.535 (39)	0.354 (9)	M8	266 (30)

*SC010 with a bore of 8mm or 0.3125" will have a M2 clamp screw and a tightening torque of 3.5 in lbs. or 0.4Nm
 • Standard bores fit an h7 shaft tolerance. Bores to fit a k6 or j6 shaft tolerance are a standard option - please specify at the time of order.

****Reduced Hub Dimensions**

Model	Min Inch (mm)	Max Inch (mm)
SC030R	0.1875 (5)	0.375 (10)
SC040R	0.3125 (8)	0.5625 (15)
SC050R	0.375 (8)	0.750 (19)
SC060R	0.4375 (11)	0.9375 (24)

**The hub in these coupling sizes will have a reduced outside diameter when smaller bore sizes are selected. The chart to the left identifies the range of bore sizes that utilize the reduced diameter hubs. Bores larger than the max listing in the chart to the left and equal to or less than the max bore in the above chart will have the standard sized hub.

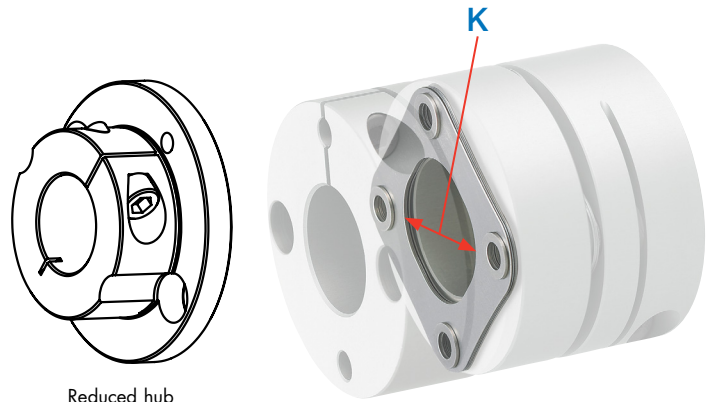

Reduced hub



- For high performance servo motor and demanding motion control applications
- High torsional stiffness for use in precision positioning applications
- Eco-Friendly, adapted to RoHS Directive with no banned substances
- Low inertia for high speed applications
- Zero backlash and low hysteresis ensures repeatable precise positioning

Single Disc Specifications

Model	Operating Torque in-lbs (Nm)	Maximum RPM rpm	Torsional Stiffness in-lbs/deg (Nm/rad)	Axial Stiffness lbs/in (N/mm)	Misalignment Capacity			Moment of Inertia lb-in ² (kgm ² × 10 ⁻⁹)	Weight ounce (gram)	Style
					Parallel inch (mm)	Angular degree	Axial ± inch ± (mm)			
SD002R	2.2 (0.25)	10,000	29 (190)	194 (34)	0.0003 (0.01)	0.5	0.001 (0.04)	0.0002 (0.06)	0.10 (3)	C
SD005R	5.3 (0.6)	10,000	77 (500)	799 (140)	0.001 (0.02)	0.5	0.002 (0.05)	0.0009 (0.26)	0.25 (7)	C
SD010R	8.9 (1.0)	10,000	216 (1,400)	799 (140)	0.001 (0.02)	1	0.004 (0.10)	0.0019 (0.58)	0.39 (11)	C
SD020R	18 (2.0)	10,000	572 (3,700)	366 (64)	0.001 (0.02)	1	0.006 (0.15)	0.008 (2.36)	0.9 (25)	C
SD025R	35 (4.0)	10,000	865 (5,600)	343 (60)	0.001 (0.02)	1	0.007 (0.19)	0.013 (3.67)	1.0 (29)	C
SD030R	44 (5.0)	10,000	1,236 (8,000)	366 (64)	0.001 (0.02)	1	0.008 (0.2)	0.014 (4.00)	1.2 (34)	A
								0.021 (6.06)	1.4 (41)	B
								0.028 (8.12)	1.7 (49)	C
SD035R	89 (10)	10,000	2,781 (18,000)	640 (112)	0.001 (0.02)	1	0.010 (0.25)	0.063 (18.4)	3.0 (84)	C
SD040R	106 (12)	10,000	3,089 (20,000)	457 (80)	0.001 (0.02)	1	0.012 (0.3)	0.056 (16.4)	2.7 (77)	A
								0.078 (23.0)	3.2 (90)	B
								0.101 (29.5)	3.7 (105)	C
SD050R	221 (25)	10,000	4,943 (32,000)	274 (48)	0.001 (0.02)	1	0.016 (0.4)	0.188 (54.9)	5.5 (156)	A
								0.263 (77.1)	6.5 (185)	B
								0.339 (99.3)	7.5 (214)	C
SD055R	354 (40)	10,000	7,723 (50,000)	245 (43)	0.001 (0.02)	1	0.016 (0.42)	0.642 (188)	11 (314)	C
								0.491 (144)	9.8 (279)	A
								0.704 (205)	11.9 (337)	B
SD060R	531 (60)	10,000	10,813 (70,000)	436 (76.4)	0.001 (0.02)	1	0.018 (0.45)	0.918 (268.6)	14 (396)	C
								0.918 (268.6)	14 (396)	C
								0.918 (268.6)	14 (396)	C
SD080R	885 (100)	10,000	21,626 (140,000)	731 (128)	0.001 (0.02)	1	0.02 (0.55)	2.43 (709.3)	25.6 (727)	C
SD090R	1,593 (180)	10,000	15,447 (100,000)	616 (108)	0.001 (0.02)	1	0.03 (0.65)	4.20 (1,227)	33.8 (959)	C
SD100R	2,213 (250)	10,000	18,535 (120,000)	664 (111)	0.001 (0.02)	1	0.03 (0.74)	6.36 (1,858)	41.6 (1,181)	C

• Moment of Inertia and Weight are measured with the maximum bore diameters

If the shafts of the equipment are smaller than the ID of the flex element they may be extended into the interior of the coupling. The ends of the shafts must never touch each other or the other hub.

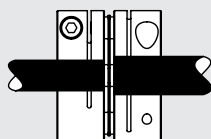

Style of coupling is dependent on the size of the coupling and bore combination selected. Therefore, the coupling could be comprised of the combinations shown to the right.



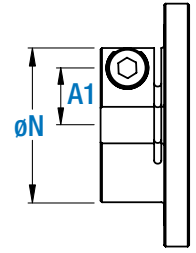
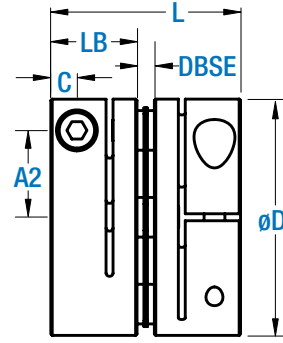
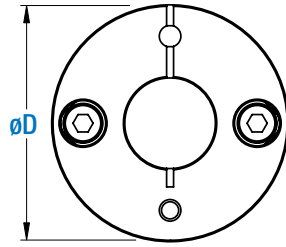
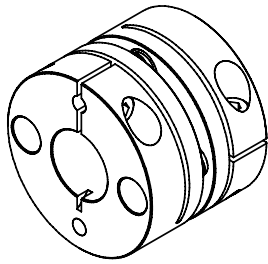

Reduced hub **

Single Disc Dimensions

Model	Bores		Outside Diameter	Overall Length	Hub Length	Reduced Hub Diameter	Distance Between Shaft Ends	Inside dia. of the flex disc	Clamp Screw to Bore (on reduced hubs)	Clamp Screw	Clamp Screw to End of Hub	Clamp Screw Size	Tightening Torque
	Min	Max											
	inch (mm)	inch (mm)	D	L	LB	N	DBSE	K	A1	A2	C	M	in-lbs (Nm)
SD002R	0.125 (3)	0.1875 (5)	0.47 (12)	0.486 (12.35)	0.232 (5.9)	-	0.021 (0.55)	0.224 (5.6)	-	0.146 (3.7)	0.074 (1.9)	M1.6	2 (0.23)
SD005R	0.125 (3)	0.1875 (6)	0.63 (16)	0.657 (16.7)	0.309 (7.85)	-	0.039 (1.0)	0.256 (6.5)	-	0.189 (4.8)	0.098 (2.5)	M2.0	3.5 (0.4)
SD010R	0.125 (3)	0.3125* (8)*	0.748 (19)	0.762 (19.35)	0.36 (9.15)	-	0.041 (1.05)	0.335 (8.5)	-	0.228 (5.8)	0.124 (3.15)	M2.5*	9* (1)*
SD020R	0.1875 (4)	0.4375 (11)	1.024 (26.0)	0.911 (23.15)	0.423 (10.75)	-	0.065 (1.65)	0.417 (10.6)	-	0.374 (9.5)	0.130 (3.3)	M2.5	9 (1)
SD025R	0.250 (5)	0.500 (14)	1.142 (29.0)	0.921 (23.4)	0.423 (10.75)	-	0.075 (1.9)	0.571 (14.5)	-	0.433 (11.0)	0.130 (3.3)	M2.5	9 (1)
SD030R	0.1875** (5)**	0.625 (16)	1.339 (34.0)	1.075 (27.3)	0.488 (12.4)	0.850 (21.6)	0.098 (2.5)	0.571 (14.5)	0.315 (8)	0.492 (12.5)	0.148 (3.75)	M3	13 (1.5)
SD035R	0.250 (6)	0.750 (19)	1.535 (39.0)	1.339 (34)	0.610 (15.5)	-	0.118 (3.0)	0.669 (17)	-	0.551 (14)	0.177 (4.5)	M4	30 (3.4)
SD040R	0.3125** (8)**	0.9375 (24)	1.732 (44.0)	1.339 (34)	0.610 (15.5)	1.165 (29.6)	0.118 (3.0)	0.768 (19.5)	0.433 (11)	0.669 (17)	0.177 (4.5)	M4	30 (3.4)
SD050R	0.375** (8)**	1.1875 (30)	2.205 (56.0)	1.709 (43.4)	0.807 (20.5)	1.496 (38)	0.094 (2.4)	1.024 (26)	0.571 (14.5)	0.866 (22)	0.236 (6)	M5	62 (7)
SD055R	0.4375 (10)	1.125 (30)	2.480 (63.0)	1.992 (50.6)	0.945 (24)	-	0.102 (2.6)	1.220 (31)	-	0.906 (23)	0.305 (7.75)	M6	123 (14)
SD060R	0.4375** (11)**	1.375 (35)	2.677 (68.0)	2.110 (53.6)	0.992 (25.2)	1.811 (46)	0.126 (3.2)	1.220 (31)	0.689 (17.5)	1.043 (26.5)	0.305 (7.75)	M6	124 (14)
SD080R	0.750 (18)	1.5625 (40)	3.228 (82.0)	2.677 (68)	1.181 (30)	-	0.315 (8)	1.496 (38)	-	1.102 (28)	0.354 (9)	M8	266 (30)
SD090R	1.000 (25)	1.750 (45)	3.622 (94.0)	2.689 (68.3)	1.181 (30)	-	0.327 (8.3)	1.654 (42)	-	1.339 (34)	0.354 (9)	M8	266 (30)
SD100R	1.3125 (32)	1.750 (45)	4.095 (104.0)	2.748 (69.8)	1.181 (30)	-	0.386 (9.8)	1.890 (48)	-	1.535 (39)	0.354 (9)	M8	266 (30)

*SD010 with a bore of 8mm or 0.3125" will have a M2 clamp screw and a tightening torque of 3.5 in lbs. or 0.4Nm
 • Standard bores fit an h7 shaft tolerance. Bores to fit a k6 or j6 shaft tolerance are a standard option - please specify at the time of order.

****Reduced Hub Dimensions**

Model	Min Inch (mm)	Max Inch (mm)
SD030R	0.1875 (5)	0.375 (10)
SD040R	0.3125 (8)	0.5625 (15)
SD050R	0.375 (8)	0.750 (19)
SD060R	0.4375 (11)	0.9375 (24)

**The hub in these coupling sizes will have a reduced outside diameter when smaller bore sizes are selected. The chart to the left identifies the range of bore sizes that utilize the reduced diameter hubs. Bores larger than the max listing in the chart to the left and equal to or less than the max bore in the above chart will have the standard sized hub.

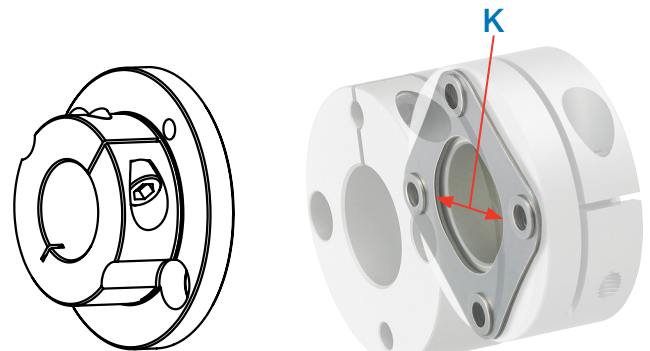

Reduced hub

The **ServoClass Floating Shaft Coupling** is a zero backlash line shaft coupling that provides high torsional stiffness and high misalignment capacity in extended length applications. Utilizing the field-proven design of the ServoClass Couplings, these Floating Shaft Couplings are ideal for motion control applications including gantry systems, connecting 2 actuators, line-shafted equipment and more. Featuring low inertia, low reaction loads, and RoHS compliance, these solutions are available in 8 standard sizes and are ideal for positioning applications that require precision and repeatability. **Contact factory for custom requirements.**



Features/Benefits:

- Zero-Backlash
- High Torsional Stiffness
- High Precision / Performance
- Low Reaction Loads
- Low Inertia
- **Made to Exact Length Requirements**

Construction:

- Aluminum Alloy Hubs
- Stainless Steel Disc-Packs
- Corrosion Resistant Fasteners
- Integral Clamping Hubs
- Precise Concentricity
- RoHS Compliance
- **Fast Delivery**

Specifications

Model	Operating Torque in-lbs (Nm)	Maximum* RPM in-lbs (Nm) <i>See Graph (Page 9)</i>	Torsional Stiffness		Misalignment Capacity			Base Unit Weight at 12" DBSE (300 mm DBSE) ounce (gram)	Base Unit Moment of Inertia at 12" DBSE (300 mm DBSE) lb-in ² (Kg-m ²)	Hub Style <i>(See Page 9)</i>	Weight Adder per inch of DBSE (Per meter of DBSE) <i>(See Note 2)</i> lb/inch (kg/meter)	Inertia Adder per inch of DBSE (Per meter of DBSE) <i>(See Note 2)</i> lb-in ² /inch (Kg-m ² /meter)
			Baseline at 12" DBSE (300 mm DBSE) <i>(See Note 1)</i> in-lbs/deg. (Nm/Rad)	Baseline at 48" DBSE (1200 mm DBSE) <i>(See Note 1)</i> in-lbs/deg. (Nm/Rad)	Parallel inch/inch of DBSE (mm/meter of DBSE)	Angular degree	Axial ± inch ± (mm)					
SF030R	44 (5.0)	10,000*	287 (1,858)	101 (655)	0.007 (0.18)	1	0.016 (0.4)	6.7 (189)	8.204 (0.0024)	A	0.024 (0.011)	0.0083 (2.4 x 10 ⁻⁶)
								6.9 (196)	8.843 (0.0026)	B		
								7.2 (204)	9.533 (0.0028)	C		
SF035R	89 (10)	10,000*	570 (3,691)	185 (1,199)	0.009 (0.24)	1	0.020 (0.5)	9.0 (255)	12.413 (0.0036)	C	0.029 (0.013)	0.0147 (4.3 x 10 ⁻⁶)
								10.2 (289)	13.574 (0.0039)	A		
								10.7 (304)	14.782 (0.0043)	B		
SF040R	106 (12)	10,000*	776 (5,025)	282 (1,828)	0.009 (0.24)	1	0.024 (0.6)	11.2 (318)	16.103 (0.0047)	C	0.034 (0.015)	0.0236 (6.9 x 10 ⁻⁶)
								16.5 (467)	26.737 (0.0078)	A		
								17.5 (496)	29.429 (0.0086)	B		
SF050R	221 (25)	6,755*	1,228 (7,951)	433 (2,806)	0.011 (0.28)	1	0.031 (0.8)	18.5 (526)	32.455 (0.0095)	C	0.039 (0.018)	0.0359 (10.5 x 10 ⁻⁶)
								26.9 (763)	48.929 (0.0143)	A		
								28.6 (811)	53.511 (0.0156)	B		
SF060R	531 (60)	5,900*	1,719 (11,130)	481 (3,117)	0.013 (0.34)	1	0.035 (0.9)	30.3 (858)	58.644 (0.0172)	C	0.049 (0.022)	0.0715 (20.9 x 10 ⁻⁶)
								66.3 (1,881)	126.726 (0.0370)	C		
								77.6 (2,199)	149.325 (0.0437)	C		
SF080R	885 (100)	5,950*	3,585 (23,213)	966 (6,455)	0.02 (0.52)	1	0.04 (1.10)	66.3 (1,881)	126.726 (0.0370)	C	0.122 (0.055)	0.1077 (31.5 x 10 ⁻⁶)
SF090R	1,593 (180)	4,920*	5,729 (37,095)	2,774 (17,978)	0.02 (0.52)	1	0.05 (1.30)	77.6 (2,199)	149.325 (0.0437)	C	0.141 (0.064)	0.4538 (132.8 x 10 ⁻⁶)
SF100R	2,213 (250)	7,930*	8,100 (52,447)	5,280 (34,219)	0.02 (0.52)	1	0.06 (1.48)	93.9 (2,661)	186.846 (0.0547)	C	0.151 (0.068)	0.2053 (60.1 x 10 ⁻⁶)

* Maximum RPM listed is at Minimum DBSE. See graph on page 9 for Max RPM/Length relationship.
 Note: 1) Contact factory for torsional stiffness value for couplings of other lengths.
 Note: 2) For weight/inertia **adders** of units longer or shorter than 12" (300mm), subtract 12" (300mm) from the DBSE and multiply by weight/inertia **adder** values listed above.

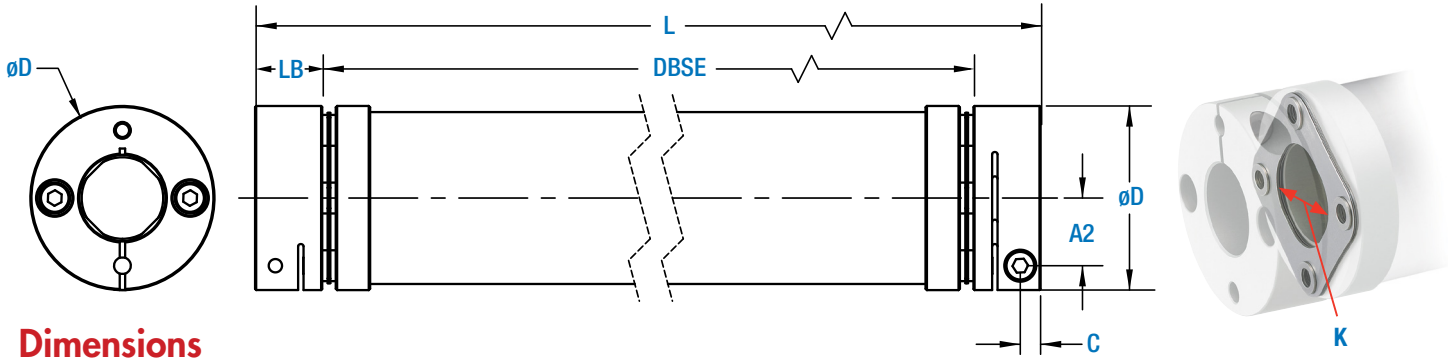

Dimensions

Model	Bores		Outside Diameter D	Hub Length LB	Reduced Hub Diameter N	Inside dia. of flex disc K	Clamp Screw to Bore (on reduced hubs) A1	Clamp Screw A2	Clamp Screw to End of Hub C	Minimum DBSE inch (mm)	Maximum* DBSE See Graph inch (mm)	Clamp Screw Size M	Tightening Torque in-lbs (Nm)
	Min inch (mm)	Max inch (mm)											
SF030R	0.1875** (5)**	0.625 (16)	1.339 (34.0)	0.488 (12.4)	0.850 (21.6)	0.571 (14.5)	0.315 (8)	0.492 (12.5)	0.148 (3.75)	1.500 (38.1)	132* (3,352)*	M3	13 (1.5)
SF035R	0.250 (6)	0.750 (19)	1.535 (39.0)	0.610 (15.5)	-	0.669 (17)	-	0.551 (14)	0.177 (4.5)	1.500 (38.1)	132* (3,352)*	M4	30 (3.4)
SF040R	0.3125** (8)**	0.9375 (24)	1.732 (44.0)	0.610 (15.5)	1.165 (29.6)	0.768 (19.5)	0.433 (11)	0.669 (17)	0.177 (4.5)	1.625 (41.3)	132* (3,352)*	M4	30 (3.4)
SF050R	0.375** (8)**	1.1875 (30)	2.205 (56.0)	0.807 (20.5)	1.496 (38)	1.024 (26)	0.571 (14.5)	0.866 (22)	0.236 (6)	2.000 (50.8)	132* (3,352)*	M5	62 (7)
SF060R	0.4375** (11)**	1.375 (35)	2.877 (68.0)	0.922 (25.2)	1.811 (46)	1.220 (31)	0.689 (17.5)	1.043 (26.5)	0.305 (7.75)	2.300 (58.4)	132* (3,352)*	M6	124 (14)
SF080R	0.750 (18)	1.5625 (40)	3.228 (82.0)	1.181 (30)	-	1.496 (38)	-	1.102 (28)	0.354 (9)	3.000 (76.2)	132* (3,352)*	M8	266 (30)
SF090R	1.000 (25)	1.750 (45)	3.622 (94.0)	1.181 (30)	-	1.654 (42)	-	1.339 (34)	0.354 (9)	3.125 (79.4)	132* (3,352)*	M8	266 (30)
SF100R	1.3125 (32)	1.750 (45)	4.095 (104.0)	1.181 (30)	-	1.890 (48)	-	1.535 (39)	0.354 (9)	3.300 (83.8)	132* (3,352)*	M8	266 (30)

NOTE: Standard bores fit an h7 shaft tolerance. Bores to fit a k6 or j6 shaft tolerance are a standard option - please specify at time of order.

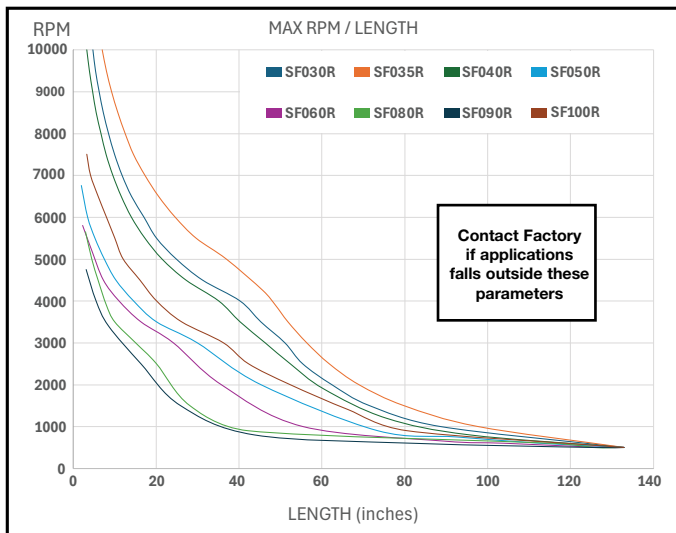

*The chart above shows lengths and speeds at which standard ServoClass Floating Shaft Couplings can operate while avoiding critical speeds and natural frequencies. Couplings at or near maximum values may require dynamic balancing.

**Reduced Hub Dimensions

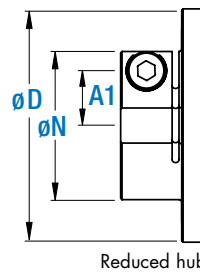

Reduced hub

Model	Min Inch (mm)	Max Inch (mm)
SF030R	0.1875 (5)	0.375 (10)
SF040R	0.3125 (8)	0.5625 (15)
SF050R	0.375 (8)	0.750 (19)
SF060R	0.4375 (11)	0.9375 (24)

**The hub in these coupling sizes will have a reduced outside diameter when smaller bore sizes are selected. The chart above identifies the range of bore sizes that utilize the reduced diameter hubs. Bores larger than the max listing in the chart above and equal to or less than the max bore for the coupling size will have the standard sized hub.

If the shafts of the equipment are smaller than the ID of the flex element they may be extended into the floating shaft coupling.

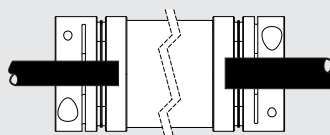

Style of coupling is dependent on the size of the coupling and bore combination selected. Therefore, the coupling could be comprised of the combinations shown to the right.



The right coupling can add performance and longevity to your system!

High Torsional Stiffness

- Increased system accuracy
- Enables high-speed operation
- Improved system stability

High Quality

- High grade materials used throughout the coupling
- Machined and assembled by highly skilled technicians with certified tooling

Low radial stiffness

- Improved bearing life
- Reduce operating temperatures
- Improved system accuracy

Ultra low weight design

- Low inertia
- High strength aluminum
- Lower inertia than comparable bellows designs

Precision designed clamp hub

- Positive shaft hub connection
- Zero backlash
- Trouble free assembly

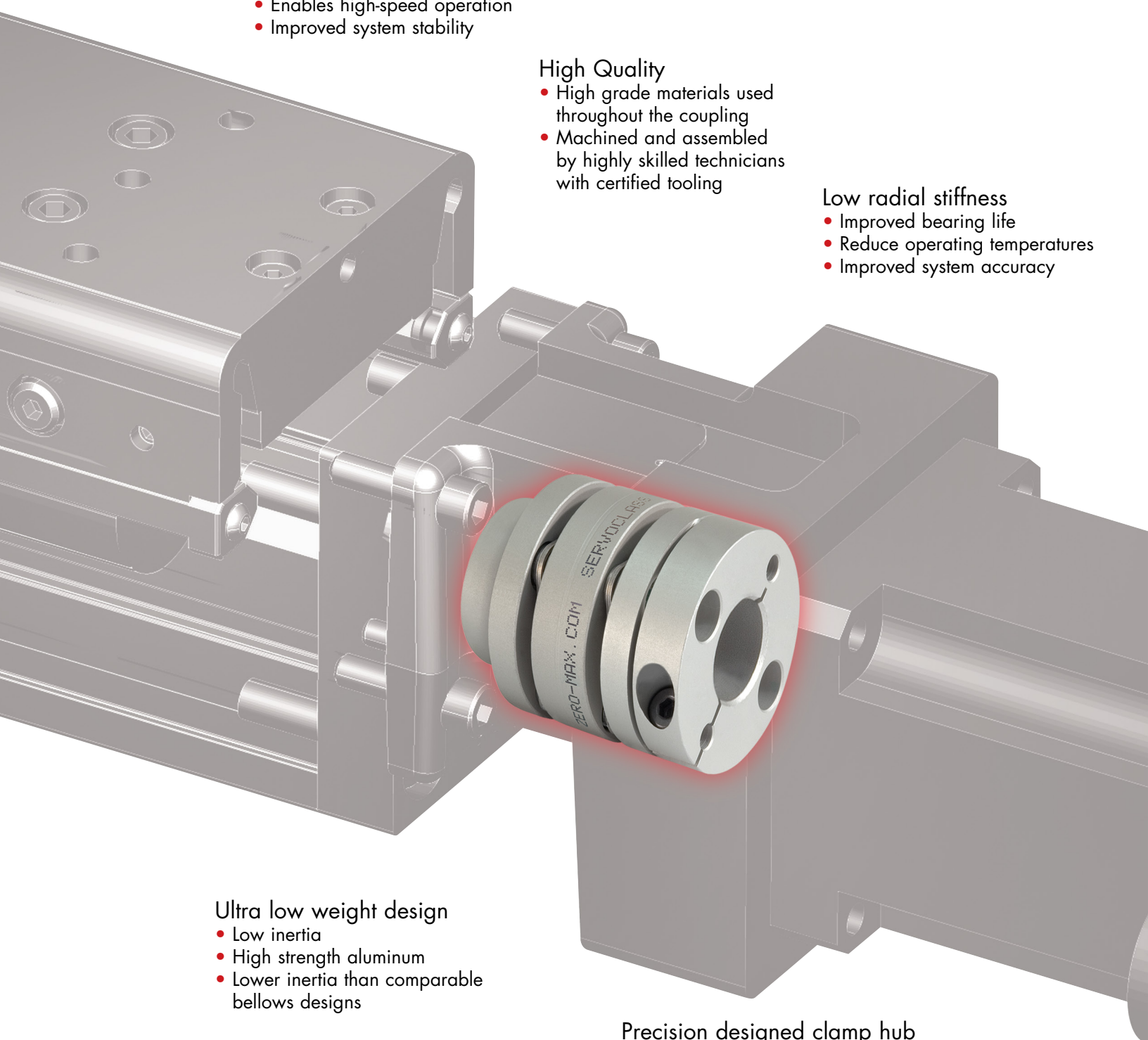

Typical Hysteresis Curves

ServoClass Coupling

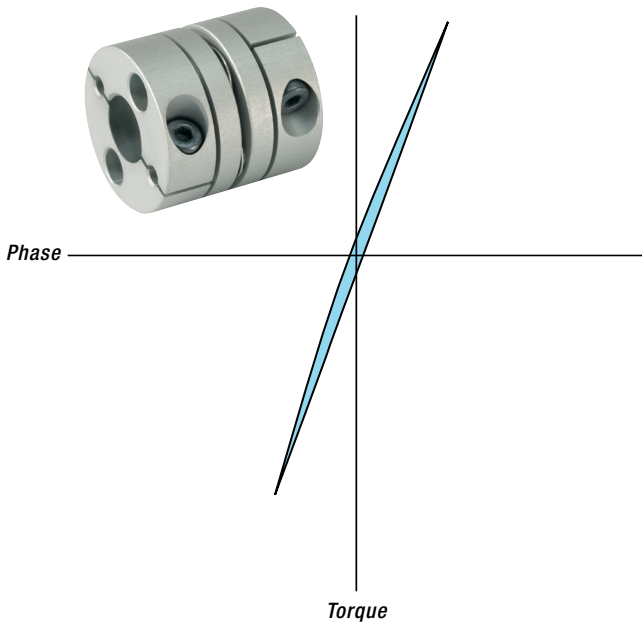

Typical "Zero backlash" Jaw Type Coupling

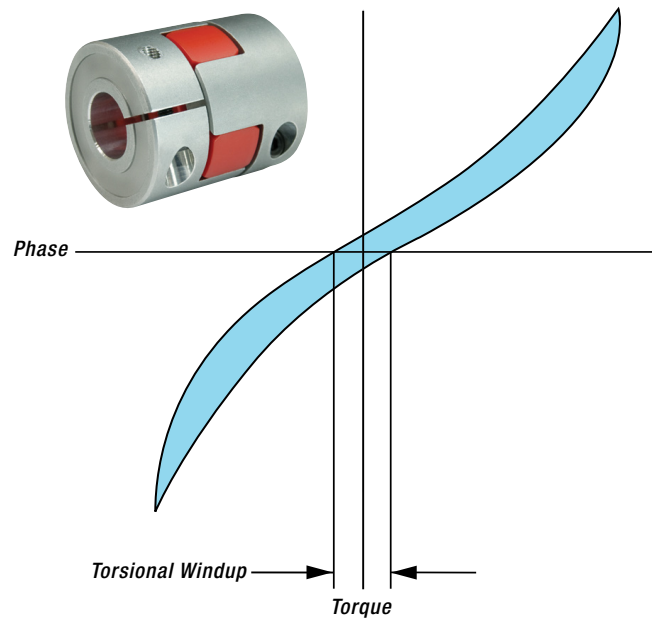

SC010R (6mm x 0.250")

Download CAD Choose a CAD format

View 3D Model Adobe 3D PDF help

Configuration

Bore Size D1 6 mm

Bore Size D2 0.2500"

The screenshot shows a 3D CAD model of the SC010R coupling in a perspective view. To the right of the model is a control panel with a title 'SC010R (6mm x 0.250")'. Below the title are two buttons: 'Download CAD' followed by a dropdown menu 'Choose a CAD format', and 'View 3D Model' followed by a link 'Adobe 3D PDF help'. At the bottom, there is a 'Configuration' section with two dropdown menus: 'Bore Size D1' set to '6 mm' and 'Bore Size D2' set to '0.2500"'. At the bottom left of the viewer are several small icons for navigation and display options.



Zero-Max Configurable
3D CAD Downloads.
www.zero-max.com

Selection Procedure

1. Calculate torque (T_a) applied to the coupling based on the motor output (P) and coupling operating rotation speed (n).

$$T_a[\text{N}\cdot\text{m}] = 9550 \times \frac{P [\text{kW}]}{n [\text{RPM}]}$$
2. Calculate corrected torque (T_d) applied to the coupling after deciding the service factor (K) based on load conditions.

$$T_d = T_a \times K$$

In servomotor drive, multiply the service factor $K=1.2\sim 1.5$ by the maximum torque of servomotor (T_s).

$$T_d = T_s \times (1.2\sim 1.5)$$
3. Select a coupling size with operating torque (T_n) greater than the corrected torque (T_d).

$$T_n \geq T_d$$
4. Depending on the bore diameters, the coupling operating torque (T_n) may be limited. Refer to the "specification" and "standard bore diameter" charts.
5. Confirm if the required shaft diameter does not exceed the maximum bore diameter of the selected coupling size.

If our standard line of ServoClass coupling will not exactly fit your system needs, contact us for a custom design.

- Custom bores
- Ultra high speeds
- Special finishes
- Special lengths
- Designed for operation in special environments

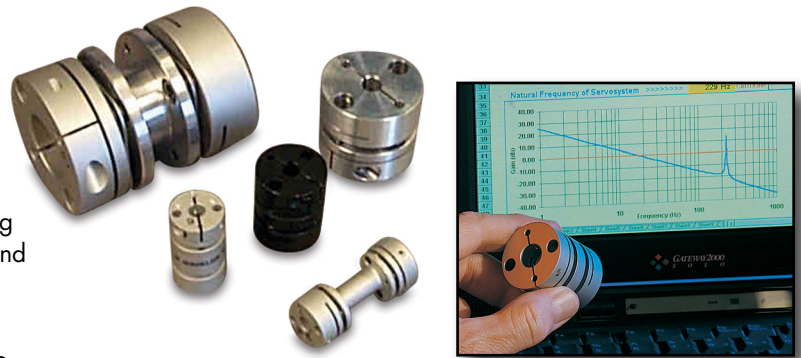

Inch Bore Size Chart

Bore inch	Model													
	SD002R SC002R	SD005R SC005R	SD010R SC010R	SD020R SC020R	SD025R SC025R	SD030R SC030R	SD035R SC035R	SD040R SC040R	SD050R SC050R	SD055R SC055R	SD060R SC060R	SD080R SC080R	SD090R SC090R	SD100R SC100R
0.125	●	●	●											
0.1875	●	●	●	●			23							
0.250			●	●	●	●	44							
0.3125			●	●	●	●	●	80						
0.375				●	●	●	●	●	195					
0.4375				○	●	●	●	●	●	301	443			
0.500					●	●	●	●	●	327	469			
0.5625						●	●	●	●	●	●			
0.625						○	●	●	●	●	●			
0.6875							○	●	●	●	●			
0.750							○	●	●	●	●	●		
0.8125								○	●	●	●	●		
0.875								○	●	●	●	●		
0.9375								○	●	●	●	●		
1.000									●	●	●	●	●	
1.0625									○	●	●	●	●	
1.125									○	●	●	●	●	
1.1875									○		●	●	●	
1.250											○	●	●	
1.3125											○	●	●	2080
1.375											○	●	●	●
1.4375												●	●	●
1.500												○	●	●
1.5625												○	●	●
1.625													●	●
1.6875													○	●
1.750													○	●

Note: The ● symbol indicates that the clamping collar will transmit the full rated torque without a keyway.
 The ○ symbol indicates that the clamping collar will transmit the full rated torque without a keyway, however, the shaft will not be able to pass through the center of the coupling due to the ID of the flex element.

A number in the square indicates that the bore is available and the torque rating of the clamp hub is reduced to the value shown in [in-lbs].
 A blank square indicates that the bore is not available for the selected coupling size.

Metric Bore Size Chart

Bore mm	Model													
	SD002R SC002R	SD005R SC005R	SD010R SC010R	SD020R SC020R	SD025R SC025R	SD030R SC030R	SD035R SC035R	SD040R SC040R	SD050R SC050R	SD055R SC055R	SD060R SC060R	SD080R SC080R	SD090R SC090R	SD100R SC100R
3	●	●	●											
4	●	●	●	●										
5	●	●	●	●	2.1	2.8								
6		●	●	●	●	3.4	5							
7			●	●	●	●	6.6							
8			●	●	●	●	●	9	18					
9				●	●	●	●	●	20					
10				●	●	●	●	●	22	31				
11				○	●	●	●	●	●	34	50			
12					●	●	●	●	●	36	51			
13					●	●	●	●	●	38	●			
14					●	●	●	●	●	●	●			
15						○	●	●	●	●	●			
16						○	●	●	●	●	●			
17							○	●	●	●	●			
18							○	●	●	●	●	●		
19							○	●	●	●	●	●	●	
20								○	●	●	●	●	●	
22								○	●	●	●	●	●	
24								○	●	●	●	●	●	
25									●	●	●	●	●	●
28									○	●	●	●	●	●
30									○	●	●	●	●	●
32											○	●	●	226
35											○	●	●	●
38												○	●	●
40												○	●	●
42													○	●
45													○	●

Note: The ● symbol indicates that the clamping collar will transmit the full rated torque without a keyway.
 The ○ symbol indicates that the clamping collar will transmit the full rated torque without a keyway, however, the shaft will not be able to pass through the center of the coupling due to the ID of the flex element.
 A number in the square indicates that the bore is available and the torque rating of the clamp hub is reduced to the value shown in [N·m].
 A blank square indicates that the bore is not available for the selected coupling size.

Part Numbering Structure

TYPE	SIZE	R	(Bore x Bore)	DBSE
Code Description	Code Description	Code	See Chart	Specify for SF series only
SC Double Flex SD Single Flex SF Floating shaft Note: SF only available in size 030, 035, 040, 050, 060, 080, 090, 100	002 Size 002 005 Size 005 010 Size 010 020 Size 020 025 Size 025 030 Size 030 035 Size 035 040 Size 040 050 Size 050 055 Size 055 060 Size 060 080 Size 080 090 Size 090 100 Size 100	RoHS Compliant Note: RoHS is the standard design	• ServoClass couplings are standard without keyways. • Keyways are available upon request. • Standard bores fit an h7 shaft tolerance. • Bores to fit a k6 or j6 shaft tolerance are a standard option - please specify at time of order	Example: SC050R (20 mm x 1/2") • Double Flex design • Size 050 • 20mm bore without keyway x 1/2" bore without keyway
Note: The hub design of ServoClass couplings will provide the necessary clamping force to secure the shaft in a dynamic application without the use of keyways. Keyways are available upon request. Please reference the bore size chart above for more details on bore sizes and torque.				

The Style of coupling is entirely dependent on the size of the coupling and bore combination selected.

PRECISE. RELIABLE. ROBUST. AVAILABLE.



CD® Couplings

High-performance couplings that outperform and outlast bellows and steel disc designs. The unique design of the composite disc enables the CD Couplings to withstand punishing applications and deliver high precision performance. Fully Customizable.



Keyless Shaft Locking Devices

ETP® keyless connections and Posi-Lok® keyless bushings provide quick, easy and accurate assembly of mounted shaft components. Both inch and metric bore sizes are available from stock.



ServoClass® Couplings

Designed for demanding servomotor applications. Zero backlash, high torsional stiffness, high speed design. Features flexible metal discs for high misalignment capacity and keyless clamp-type mounting hubs.

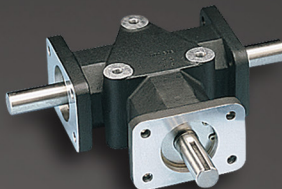

Crown Gear Drives

Available in 5-sizes, 3 configurations, and with 1:1 and 2:1 ratios. High quality AGMA class 10 spiral bevel gears. Stainless steel shafts and either black anodized or IP65-Rated nickel-plated aluminum housing.



Schmidt Offset Couplings

Designed to handle high amounts (up to 17") of parallel shaft offset with constant angular velocity. Standard models with torque capacities up to 459,000 in-lbs and extensive custom capabilities.



Adjustable Speed Drives

Easy to install and maintenance free. Zero-Max® Drives offer infinitely variable speeds from 0 rpm to 1/4 of input rpm. 5 models with torque ranges from 12 in-lbs to 200 in-lbs.

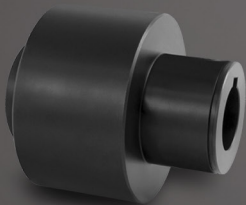

Overload Safety Couplings

Torque Tender® Couplings provide reliable overload protection in any mechanical power transmission system. Full selection of styles and sizes with set-point torque ranges from 3 to 3,000 in-lbs.



Roh'Lix® Linear Actuators

Simple conversion of rotary motion into precise linear motion. Available in five models and multiple configurations. Roh'Lix actuators have thrust ratings from 5 to 200 lbs. All models feature built-in overload protection.



Control-Flex Couplings

Zero backlash couplings designed for encoder and instrumentation type applications. Features high misalignment capacity, constant velocity, and an electrically isolated hub design.

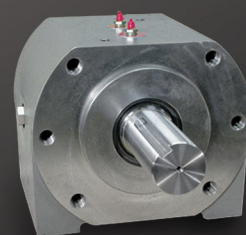

OHLA® Overhung Load Adaptors

Designed to protect hydraulic motors and pumps from radial/axial loads and to provide additional seal protection. 11 models available for mounts from SAE A to SAE F. Fully customizable.

Warranty. Zero-Max, Inc. the manufacturer, warrants that for a period of 12 months from date of shipment it will repair, or at its option, replace any new apparatus which proves defective in material or workmanship, or which does not conform to applicable drawings and specifications approved by the manufacturer. All repairs and replacements shall be F.O.B. factory. All claims must be made in writing to the manufacturer. ● In no event and under no circumstances shall manufacturer be liable for (a) damages in shipment; (b) failures or damages due to misuse, abuse, improper installation or abnormal conditions of temperature, dirt, water or corrosives; (c) failures due to operation, intentional or otherwise, above rated capacities, and (d) non-authorized expenses for removal, inspection, transportation, repair or rework. Nor shall manufacturer ever be liable for consequential and incidental damages, or in any amount greater than the purchase price of the apparatus. ● Zero Max, Inc. reserves the right to discontinue models or to change specifications at any time without notice. No discontinuance or change shall create any liability on the part of Zero-Max, Inc. in respect to its products in the hands of customers or products on order not incorporating such changes even though delivered after any such change. ● This warranty is in LIEU OF ALL OTHER WARRANTIES, EXPRESS OR IMPLIED, INCLUDING (BUT NOT LIMITED TO) ANY IMPLIED WARRANTIES OF MERCHANTABILITY OR FITNESS FOR A PARTICULAR PURPOSE. THE TERMS OF THIS WARRANTY CONSTITUTE ALL BUYER'S OR USER'S SOLE AND EXCLUSIVE REMEDY, AND ARE IN LIEU OF ANY RIGHT TO RECOVER FOR NEGLIGENCE, BREACH OF WARRANTY, STRICT TORT LIABILITY OR UPON ANY OTHER THEORY. Any legal proceedings arising out of the sale or use of this apparatus must be commenced within 18 months of the date of purchase. ● CAUTION: Rotating equipment must be guarded. Also refer to OSHA specifications and recommendations. ● Zero-Max®, CD®, ETP®, ServoClass®, Torq-Tender®, Posi-Lok®, Roh'Lix®, and OHLA® are registered trademarks of Zero-Max, Inc. In U.S.A.

©Zero-Max, Inc., All Rights Reserved
Printed in U.S.A., Rev1.085

////// ZERO-MAX®

13200 Sixth Avenue North, Plymouth, Minnesota 55441-5509
Phone 800.533.1731 763.546.4300 FAX 763.546.8260

zero-max.com