

////// ZERO-MAX[®]

ServoClass[®]-HSN Couplings



ServoClass®-HSN Resonance/Vibration Damping Couplings

- ServoClass-HSN Couplings provide **stable control** in stepper/servo motor applications that are experiencing higher levels of vibration/noise
- Ideal for **precise, high speed** operation such as linear actuator applications
- **Zero backlash** and low hysteresis ensure repeatable, precise positioning
- **Optimal torsional stiffness** for high performance use in high-gain dynamic applications
- **Low inertia** for high-speed applications
- **Low reaction loads** reduce stress and increase system lifespan
- **Eco-Friendly**, RoHS Compliant with no banned substances

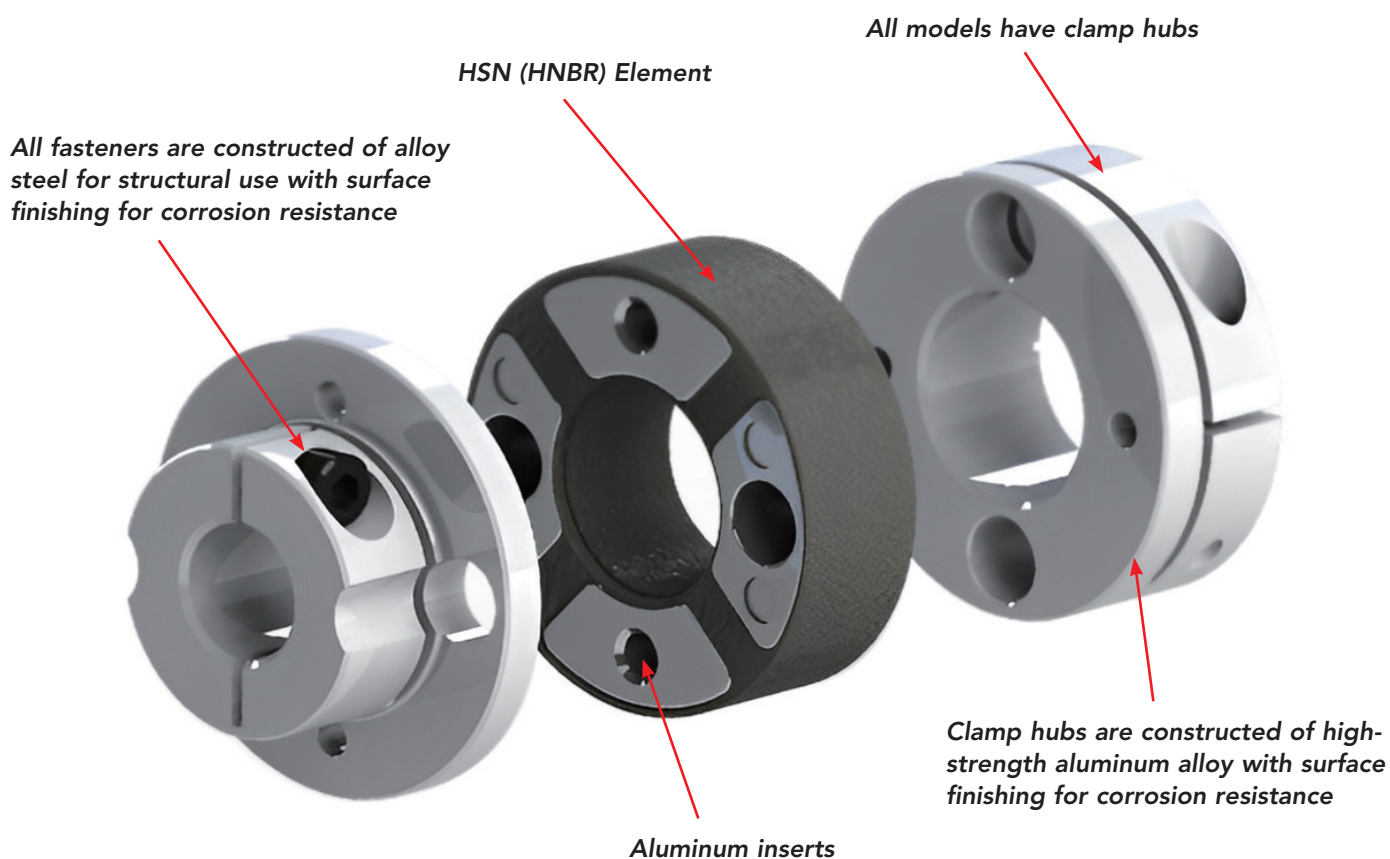

- Utilizes field-proven ServoClass clamping hub system
- Operating temperature range is -4° to +176°F (-20° to +80°C)
- Torque ratings range from 5 to 25Nm (44 to 221 in-lb)
- Tapered hub and special bore/tolerances available
- Center element constructed of Highly Saturated Nitrile (HSN/ HNBR) for maximum damping and performance
- Hubs manufactured of aluminum alloy for strength, durability, and are treated to prevent oxidation and to preserve appearance
- Couplings are precisely assembled using high strength, corrosion resistant fasteners
- Integral clamp style hubs provide fast, easy mounting, and a secure shaft connection
- RoHS compliant – manufactured of RoHS compliant materials and contains no banned substances

The Zero-Max ServoClass flexible shaft coupling line is known worldwide for its reliable high-performance operation. The new ServoClass-HSN series adds a focused anti-vibration coupling option to the traditional ServoClass metal disc model line-up. Combining the increased damping coefficient of the HSN (HNBR) center element with the proven ServoClass clamping hub design, this coupling is ideal for applications that will benefit from its superior vibration damping aspects to avoid resonance and noise.



ServoClass-HSN Coupling

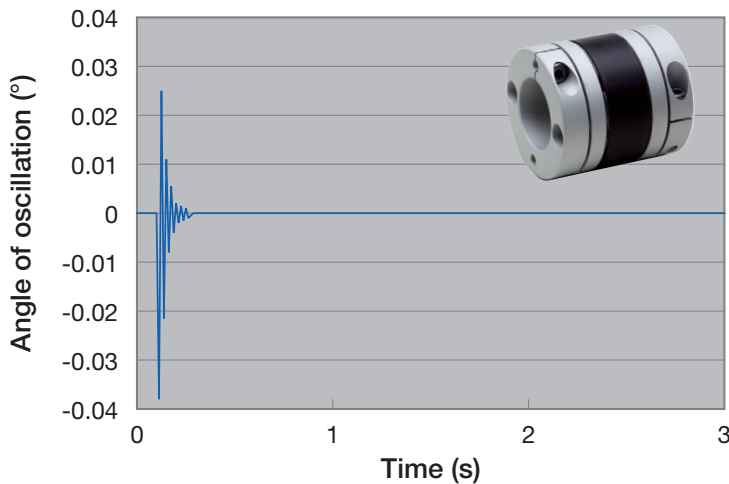

Attributes of the ServoClass-HSN

- High Damping Performance
- Zero-Backlash
- Good Torsional Stiffness
- High Misalignment Capacity
- Low Reaction Loads
- Low Inertia
- Low Hysteresis
- Electrical Isolation
- Fast, Easy Installation

The ServoClass-HSN high-damping couplings can be used for high-speed, high-precision operation required in many stepper motor and servo motor applications. The integrated center element quickly dampens vibration. In addition to providing stable high-speed control that can avoid resonance in a wide range of operating speeds, the ServoClass-HSN Coupling offers high misalignment capacity and reduces the reaction loads on the system in comparison to other resonance damping couplings.

Applications that are tightly controlled with high-gain, high-speed frequency response and having lower natural frequency driven components may benefit from the damping characteristics of the ServoClass-HSN. Applications may be found in semiconductor processing equipment, robotics, X-Y systems, and material handling equipment, among many other high performance applications.

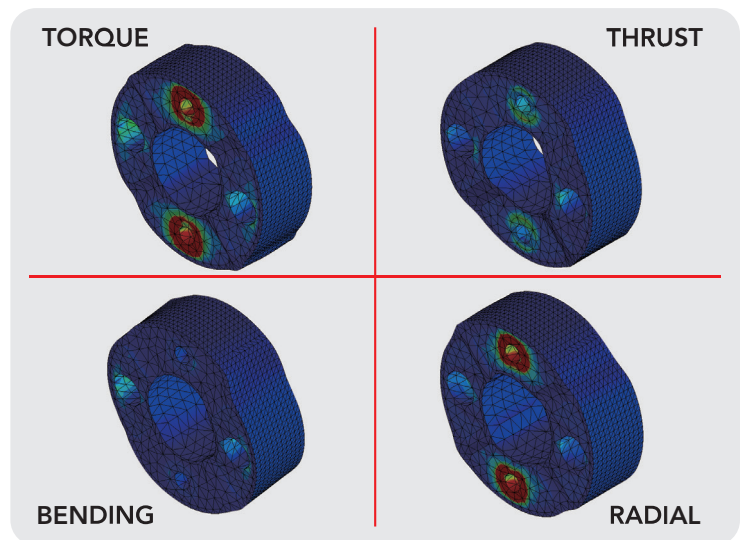

Design optimized using the latest CAE system, FEM

- For high-speed, high-gain stepper motor and servo motor motion control applications that are experiencing higher levels of vibration and noise
- Highly Saturated Nitrile (HSN) material integrated into the center element damps vibration/noise better than alternatives
- Zero backlash and low hysteresis ensures repeatable precise positioning
- Design provides high misalignment capacity with minimal reaction loads
- Eco-Friendly, meets RoHS Directive with no banned substances
- **Perfect for use with high-speed actuator systems!**

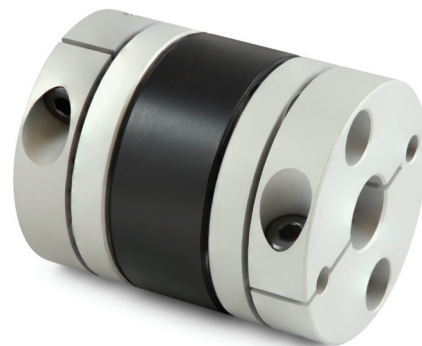

Specifications

Model	Rated Torque in-lbs (Nm)	Maximum RPM rpm	Torsional Stiffness in-lbs/deg (Nm/rad)	Axial Stiffness lbs/in (N/mm)	Misalignment Capacity			Moment of Inertia lb-in ² (kgm ² x 10 ⁻⁶)	Weight ounce (gram)	Style
					Parallel inch (mm)	Angular degree	Axial ± inch ± (mm)			
SN030R	44 (5.0)	10,000	61 (396)	2,358 (413)	0.008 (0.2)	1.5	0.012 (0.3)	0.023 (6.62)	1.7 (48)	A
								0.030 (8.65)	1.9 (54)	B
								0.037 (10.76)	2.2 (63)	C
SN035R	89 (10)	10,000	94 (607)	2,375 (416)	0.008 (0.2)	1.5	0.012 (0.3)	0.092 (26.98)	3.7 (105)	C
SN040R	106 (12)	10,000	174 (1,128)	3,455 (605)	0.008 (0.2)	1.5	0.012 (0.3)	0.087 (25.37)	3.6 (103)	A
								0.109 (31.96)	4.0 (114)	B
								0.132 (38.64)	4.5 (128)	C
SN050R	221 (25)	10,000	429 (2,775)	3,757 (658)	0.008 (0.2)	1.5	0.012 (0.3)	0.292 (85.36)	7.6 (216)	A
								0.361 (105.75)	8.3 (234)	B
								0.439 (128.36)	9.3 (263)	C

- Check the standard bore diameter list as rated torque may be restricted by the holding power of the shaft connection component.
- Torsional stiffness values are analysis values for the element taken at a temperature of 68°F (20°C).
- The moment of inertia and weight are measured at the maximum bore diameters.

Style of coupling (Style A/B/C) is dependent on the size of the coupling and bore combination selected, and is not selectable. Therefore, the coupling could be comprised of the hub combinations shown to the right.



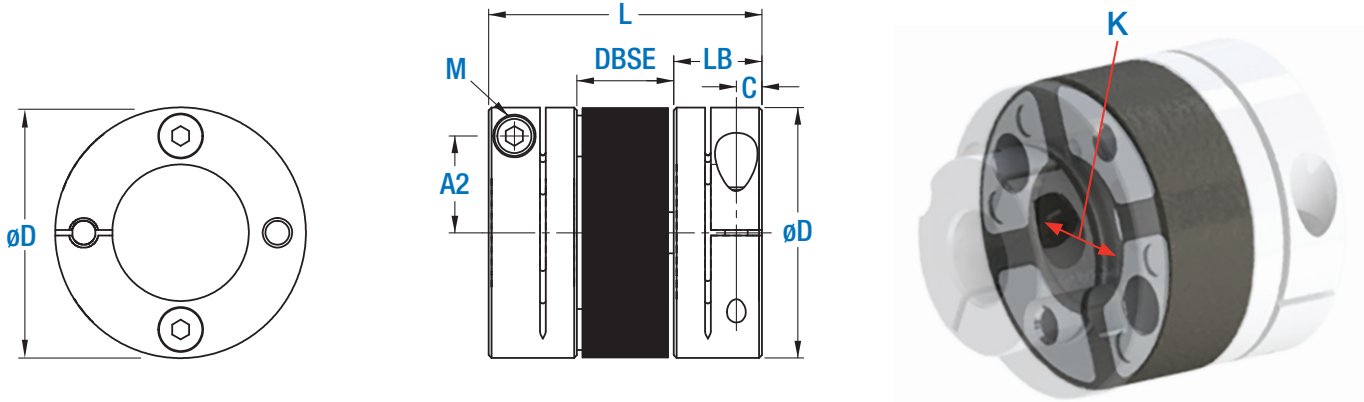

Dimensions

Model	Bores		Outside Diameter D	Overall Length L	Hub Length LB	Reduced Hub Diameter N	Distance Between Shaft Ends DBSE	Inside dia. of center element K	Clamp Screw to Bore (on reduced hubs) A1	Clamp Screw A2	Clamp Screw to End of Hub C	Clamp Screw Size M	Tightening Torque in-lbs (Nm)
	Min inch (mm)	Max inch (mm)											
SN030R	0.1875** (5)**	0.625 (16)	1.339 (34.0)	1.488 (37.8)	0.488 (12.4)	0.850 (21.6)	0.511 (13.0)	0.610 (15.5)	0.315 (8)	0.492 (12.5)	0.148 (3.75)	M3	13 (1.5)
SN035R	0.250 (6)	0.750 (19)	1.535 (39.0)	1.890 (48)	0.610 (15.5)	-	0.669 (17.0)	0.728 (18.5)	-	0.551 (14)	0.177 (4.5)	M4	30 (3.4)
SN040R	0.3125** (8)**	0.9375 (24)	1.732 (44.0)	1.890 (48)	0.610 (15.5)	1.165 (29.6)	0.669 (17.0)	0.925 (23.5)	0.433 (11)	0.669 (17)	0.177 (4.5)	M4	30 (3.4)
SN050R	0.375** (8)**	1.1875 (30)	2.205 (56.0)	2.354 (59.8)	0.807 (20.5)	1.496 (38)	0.740 (18.8)	1.161 (29.5)	0.571 (14.5)	0.866 (22)	0.236 (6)	M5	62 (7.0)

• Standard bores fit an h7 shaft tolerance. Bores to fit a k6 or j6 shaft tolerance are a standard option - please specify at the time of order.

****Reduced Hub Dimensions**

Model	Min Inch (mm)	Max Inch (mm)
SN030R	0.1875 (5)	0.375 (10)
SN040R	0.3125 (8)	0.5625 (15)
SN050R	0.375 (8)	0.750 (19)

**The hub in these coupling sizes will have a reduced outside diameter when small bore sizes are selected. The chart to the left identifies the range of bore sizes that utilize the reduced diameter hubs. Bores larger than the max listing in the chart to the left and equal to or less than the max bore in the above chart will have the standard sized hub.

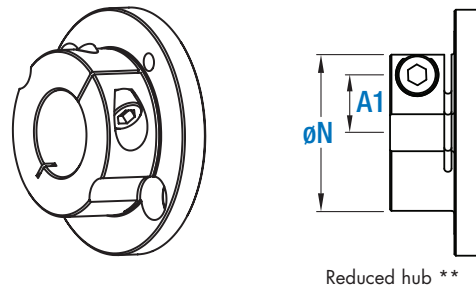

The "K" dimension is the inner diameter of the center element. If the shafts of the equipment are smaller than the ID of the center element they may be extended into the interior of the coupling. The ends of the shafts (and keys, if used) must never touch or interfere with the center element, opposite shaft, the opposite hub.

Selection Procedure

1. Calculate torque (T_a) applied to the coupling based on the motor output (P) and coupling operating rotation speed (n).

$$T_a[\text{N}\cdot\text{m}] = 9550 \times \frac{P[\text{kW}]}{n[\text{RPM}]}$$
2. Calculate corrected torque (T_d) applied to the coupling after deciding the service factor (K) based on load conditions.

$$T_d = T_a \times K$$

In servomotor drive, multiply the service factor $K=1.2\sim 1.5$ by the maximum torque of servomotor (T_s).

$$T_d = T_s \times (1.2\sim 1.5)$$
3. Select a coupling size with operating torque (T_n) greater than the corrected torque (T_d).

$$T_n \geq T_d$$
4. Depending on the bore diameters, the coupling operating torque (T_n) may be limited. Refer to the "specification" and "standard bore diameter" charts.
5. Confirm if the required shaft diameter does not exceed the maximum bore diameter of the selected coupling size.

ServoClass-HSN Options

Standard bores for the ServoClass-HSN are keyless and the hubs are designed to fit on a keyless shaft. Keyways can be added to coupling hubs if specified at time of order (for nominal charge).

Standard bores for the ServoClass-HSN fit a standard h7 shaft tolerance. Special shaft tolerances are available.

Tapered shaft adaptors are available. Contact Factory

Tapered shaft adaptor

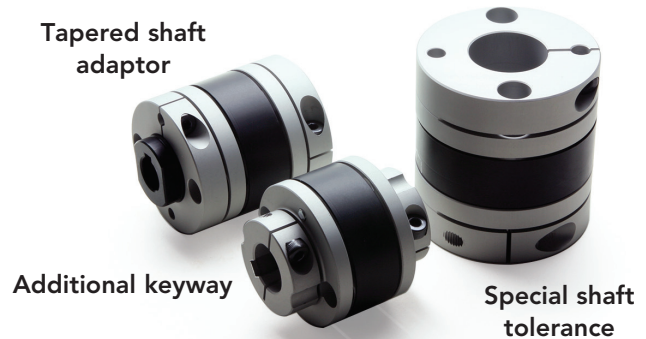

Additional keyway

Special shaft tolerance

Inch Bore Size Chart

Model	0.1875	0.250	0.3125	0.375	0.4375	0.500	0.5625	0.625	0.6875	0.750	0.8125	0.875	0.9375	1.000	1.0625	1.125	1.1875
SN030R	23	●	●	●	●	●	●	○									
SN035R	44	●	●	●	●	●	●	●	●	○							
SN040R		80	●	●	●	●	●	●	●	●	●	○					
SN050R			195	●	●	●	●	●	●	●	●	●	●	●	●	●	○

Metric Bore (mm) Size Chart

Model	5	6	7	8	9	10	11	12	13	14	15	16	17	18	19	20	22	24	25	28	30
SN030R	2.8	3.4	●	●	●	●	●	●	●	●	●	○									
SN035R		5	6.6	●	●	●	●	●	●	●	●	●	●	●	○						
SN040R				9	●	●	●	●	●	●	●	●	●	●	●	●	●	○			
SN050R				18	20	22	●	●	●	●	●	●	●	●	●	●	●	●	●	●	○

Note: The ● symbol indicates that the clamping collar will transmit the full rated torque without a keyway.

The ○ symbol indicates that the clamping collar will transmit the full rated torque without a keyway, however, the shaft will not be able to pass through the center of the coupling due to the ID of the center element.

A number in the square indicates that the bore is available and the torque rating of the clamp hub is reduced to the value shown (**in-lb** for Inch Bores and **Nm** for Metric Bores).

A blank square indicates that the bore is not available for the selected coupling size.

Part Numbering Structure

TYPE	SIZE	R	(Bore x Bore)
Code Description	Code Description	Code	See Chart
SN ServoClass-HSN	030 Size 030 035 Size 035 040 Size 040 050 Size 050	RoHS Compliant Note: RoHS is the standard design	<ul style="list-style-type: none"> • ServoClass couplings are standard without keyways. • Keyways are available upon request. • Standard bores fit an h7 shaft tolerance. • Bores to fit a k6 or j6 shaft tolerance are a standard option - please specify at time of order

Example:
SN030R
(12 mm x 1/2")

- ServoClass-HSN Model
- Size 030
- 12mm bore without keyway x 1/2" bore without keyway

Note: The hub design of ServoClass couplings will provide the necessary clamping force to secure the shaft in a dynamic application without the use of keyways. Keyways are available upon request. Please reference the bore size chart above for more details on bore sizes and torque.

The Style of coupling is entirely dependent on the size of the coupling and bore combination selected.

PRECISE. RELIABLE. ROBUST. AVAILABLE.

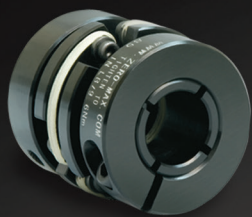

CD® Couplings

High-performance couplings that outperform and outlast bellows and steel disc designs. The unique design of the composite disc enables the CD Couplings to withstand punishing applications and deliver high precision performance. Fully Customizable.



Keyless Shaft Locking Devices

ETP® keyless connections and Posi-Lok® keyless bushings provide quick, easy and accurate assembly of mounted shaft components. Both inch and metric bore sizes are available from stock.



ServoClass® Couplings

Designed for demanding servomotor applications. Zero backlash, high torsional stiffness, high speed design. Features flexible metal discs for high misalignment capacity and keyless clamp-type mounting hubs.

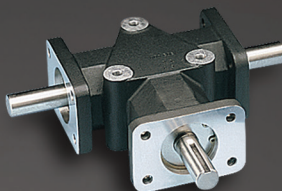

Crown Gear Drives

Available in 5-sizes, 3 configurations, and with 1:1 and 2:1 ratios. High quality AGMA class 10 spiral bevel gears. Stainless steel shafts and either black anodized or IP65-Rated nickel-plated aluminum housing.



Schmidt Offset Couplings

Designed to handle high amounts (up to 17") of parallel shaft offset with constant angular velocity. Standard models with torque capacities up to 459,000 in-lbs and extensive custom capabilities.



Adjustable Speed Drives

Easy to install and maintenance free. Zero-Max® Drives offer infinitely variable speeds from 0 rpm to 1/4 of input rpm. 5 models with torque ranges from 12 in-lbs to 200 in-lbs.

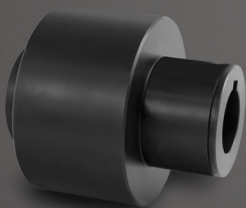

Overload Safety Couplings

Torque Tender® Couplings provide reliable overload protection in any mechanical power transmission system. Full selection of styles and sizes with set-point torque ranges from 3 to 3,000 in-lbs.



Roh'Lix® Linear Actuators

Simple conversion of rotary motion into precise linear motion. Available in five models and multiple configurations. Roh'Lix actuators have thrust ratings from 5 to 200 lbs. All models feature built-in overload protection.



Control-Flex Couplings

Zero backlash couplings designed for encoder and instrumentation type applications. Features high misalignment capacity, constant velocity, and an electrically isolated hub design.

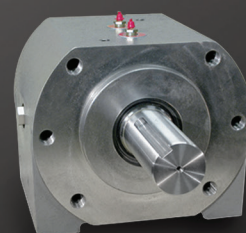

OHLA® Overhung Load Adaptors

Designed to protect hydraulic motors and pumps from radial/axial loads and to provide additional seal protection. 11 models available for mounts from SAE A to SAE F. Fully customizable.

Warranty. Zero-Max, Inc. the manufacturer, warrants that for a period of 12 months from date of shipment it will repair, or at its option, replace any new apparatus which proves defective in material or workmanship, or which does not conform to applicable drawings and specifications approved by the manufacturer. All repairs and replacements shall be F.O.B. factory. All claims must be made in writing to the manufacturer. ● In no event and under no circumstances shall manufacturer be liable for (a) damages in shipment; (b) failures or damages due to misuse, abuse, improper installation or abnormal conditions of temperature, dirt, water or corrosives; (c) failures due to operation, intentional or otherwise, above rated capacities, and (d) non-authorized expenses for removal, inspection, transportation, repair or rework. Nor shall manufacturer ever be liable for consequential and incidental damages, or in any amount greater than the purchase price of the apparatus. ● Zero Max, Inc. reserves the right to discontinue models or to change specifications at any time without notice. No discontinuance or change shall create any liability on the part of Zero-Max, Inc. in respect to its products in the hands of customers or products on order not incorporating such changes even though delivered after any such change. ● This warranty is in LIEU OF ALL OTHER WARRANTIES, EXPRESS OR IMPLIED, INCLUDING (BUT NOT LIMITED TO) ANY IMPLIED WARRANTIES OF MERCHANTABILITY OR FITNESS FOR A PARTICULAR PURPOSE. THE TERMS OF THIS WARRANTY CONSTITUTE ALL BUYER'S OR USER'S SOLE AND EXCLUSIVE REMEDY, AND ARE IN LIEU OF ANY RIGHT TO RECOVER FOR NEGLIGENCE, BREACH OF WARRANTY, STRICT TORT LIABILITY OR UPON ANY OTHER THEORY. Any legal proceedings arising out of the sale or use of this apparatus must be commenced within 18 months of the date of purchase. ● CAUTION: Rotating equipment must be guarded. Also refer to OSHA specifications and recommendations. ● Zero-Max®, CD®, ETP®, ServoClass®, Torq-Tender®, Posi-Lok®, Roh'Lix®, and OHLA® are registered trademarks of Zero-Max, Inc. In U.S.A.

©Zero-Max, Inc., All Rights Reserved
Printed in U.S.A., Rev1.025

////// ZERO-MAX®

13200 Sixth Avenue North, Plymouth, Minnesota 55441-5509
Phone 800.533.1731 763.546.4300 FAX 763.546.8260

zero-max.com